

Point Table				Point Table				Point Table				Point Table			
Point #	Zone	Northing	Easting	Point #	Zone	Northing	Easting	Point #	Zone	Northing	Easting	Point #	Zone	Northing	Easting
001	34H	6353766.6504	399913.8680	a	34H	6351713.9500	400770.5000	aa	34H	6354771.1500	400710.1800	aaa	34H	6353945.2100	401671.7000
002	34H	6354129.1341	400722.8409	b	34H	6354771.2500	400710.1700	bb	34H	6354643.8300	401108.6500	bbb	34H	6353943.7200	401793.3000
003	34H	6354337.8088	401188.5392	c	34H	6354861.6000	400495.1100	cc	34H	6354274.4100	401205.0900	ccc	34H	6353138.2200	402882.8900
				d	34H	6352943.7400	399477.0700	dd	34H	6354035.3000	401416.0200	ddd	34H	6353144.3600	403250.0500
				e	34H	6351746.0800	400105.8400	ee	34H	6353945.3100	401671.7000	eee	34H	6352948.0200	403428.8300
								ff	34H	6351666.6201	401716.7376	fff	34H	6352549.9400	403470.5200
								gg	34H	6351638.2100	402323.8600	ggg	34H	6351638.2100	402323.8600
								hh	34H	6351666.6201	401716.7376	hhh	34H	6351666.6201	401716.7376

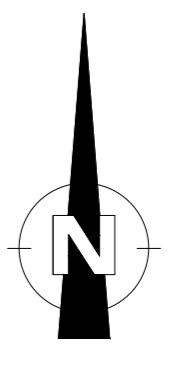

- LEGEND:**
- SCATEC PLANT BOUNDARY
 - PV SITE BOUNDARY
 - INTERNAL FENCING
 - SUBSTATION INTERNAL BOUNDARY
 - SUBSTATION BOUNDARY 10m OFFSET BUFFER
 - ACCESS ROAD CORRIDOR
 - LAYDOWN AREA

- SENSITIVITY AREAS**
- 100m BUFFER FROM RIPARIAN WATERCOURSE
 - RIPARIAN
 - RIVERINE RABBIT HIGH SENSITIVITY
 - AVIFAUNA - NO GO
 - TERRESTRIAL
 - VISUAL - NO GO
 - RIVERINE RABBIT - NO GO

- 6m GRAVEL ROAD
- 3m GRAVEL ROAD
- 2.5m GRAVEL ROAD
- FENCE
- INVERTER TRANSFORMER STATION (I.T.S)
- TRACKER PV TABLE 2 STRING (56 MODULES)

NOTE:
Coordinate System UTM WGS84

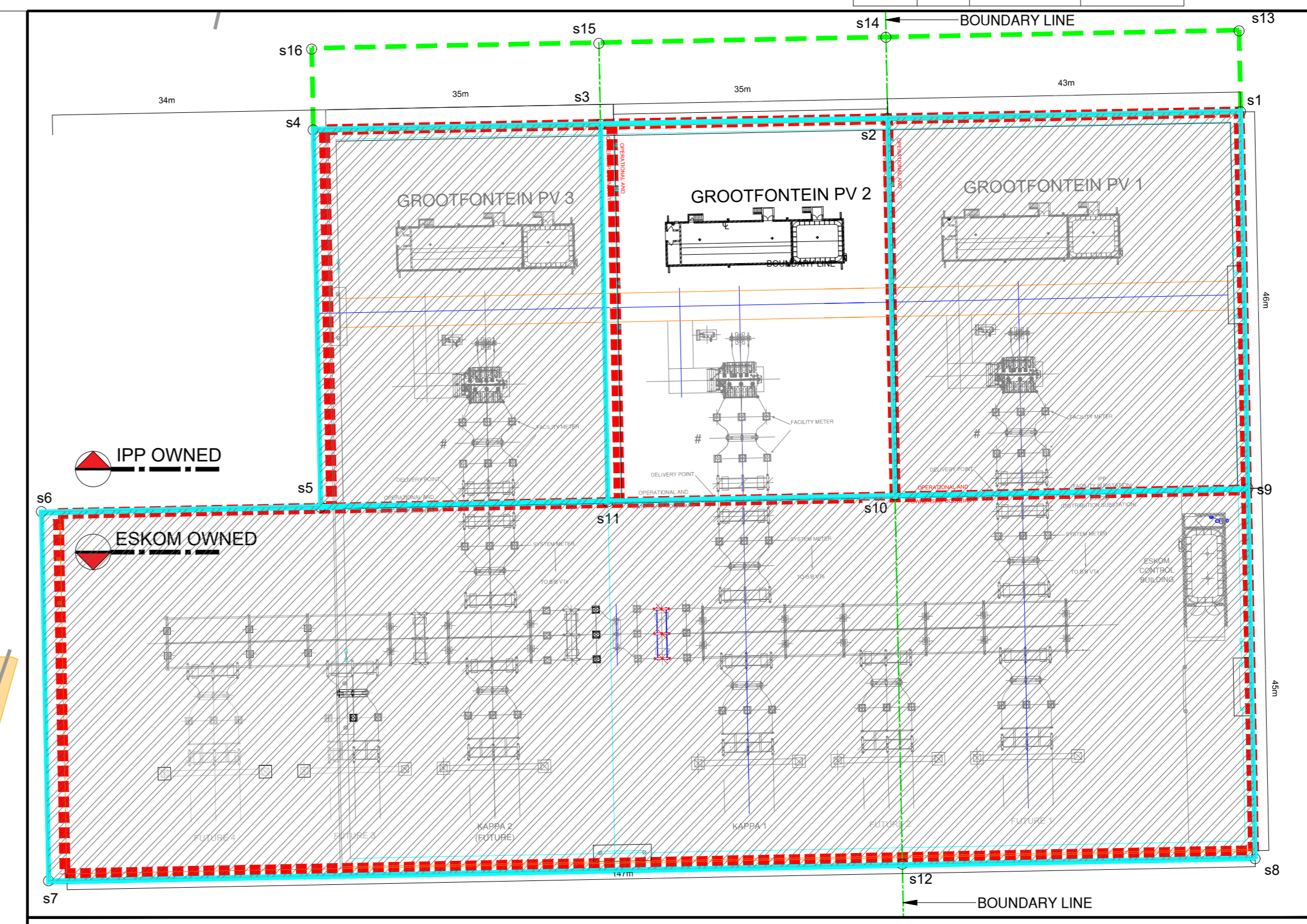

SUBSTATION

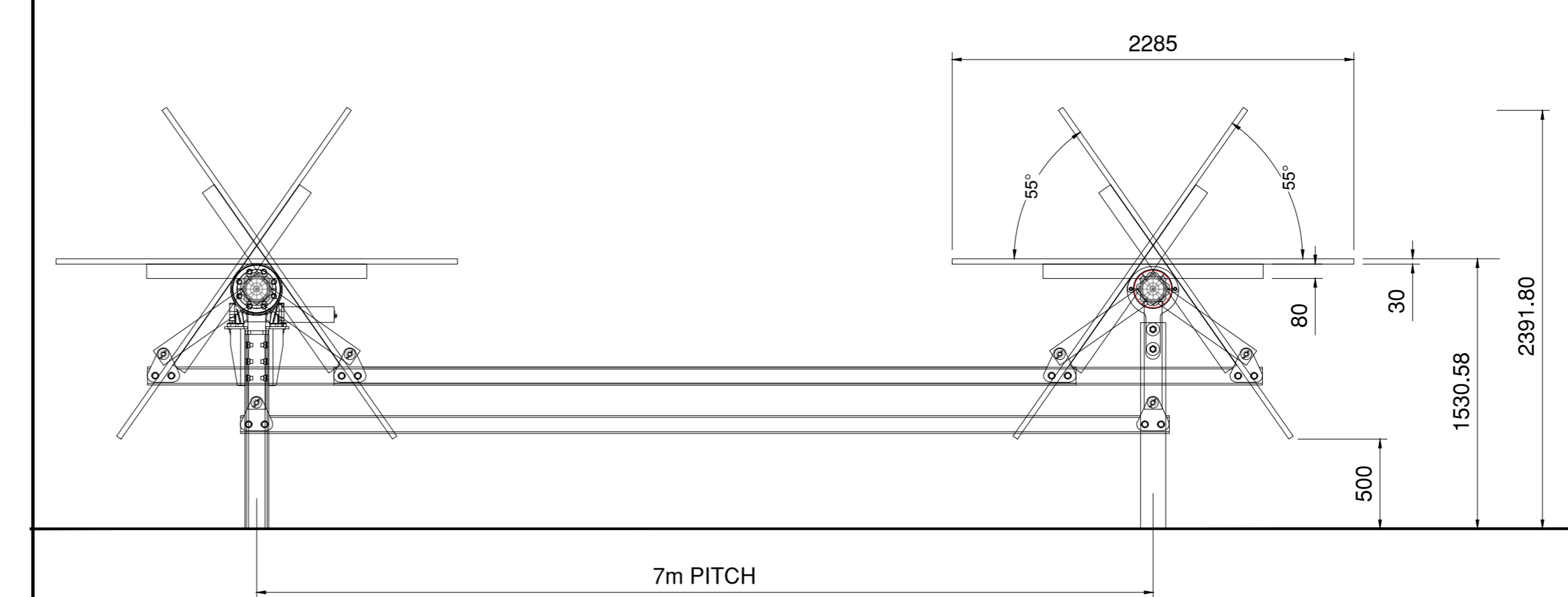

**TYPICAL TRACKER DETAIL
(1 MODULE IN PORTRAIT 7m PITCH)**

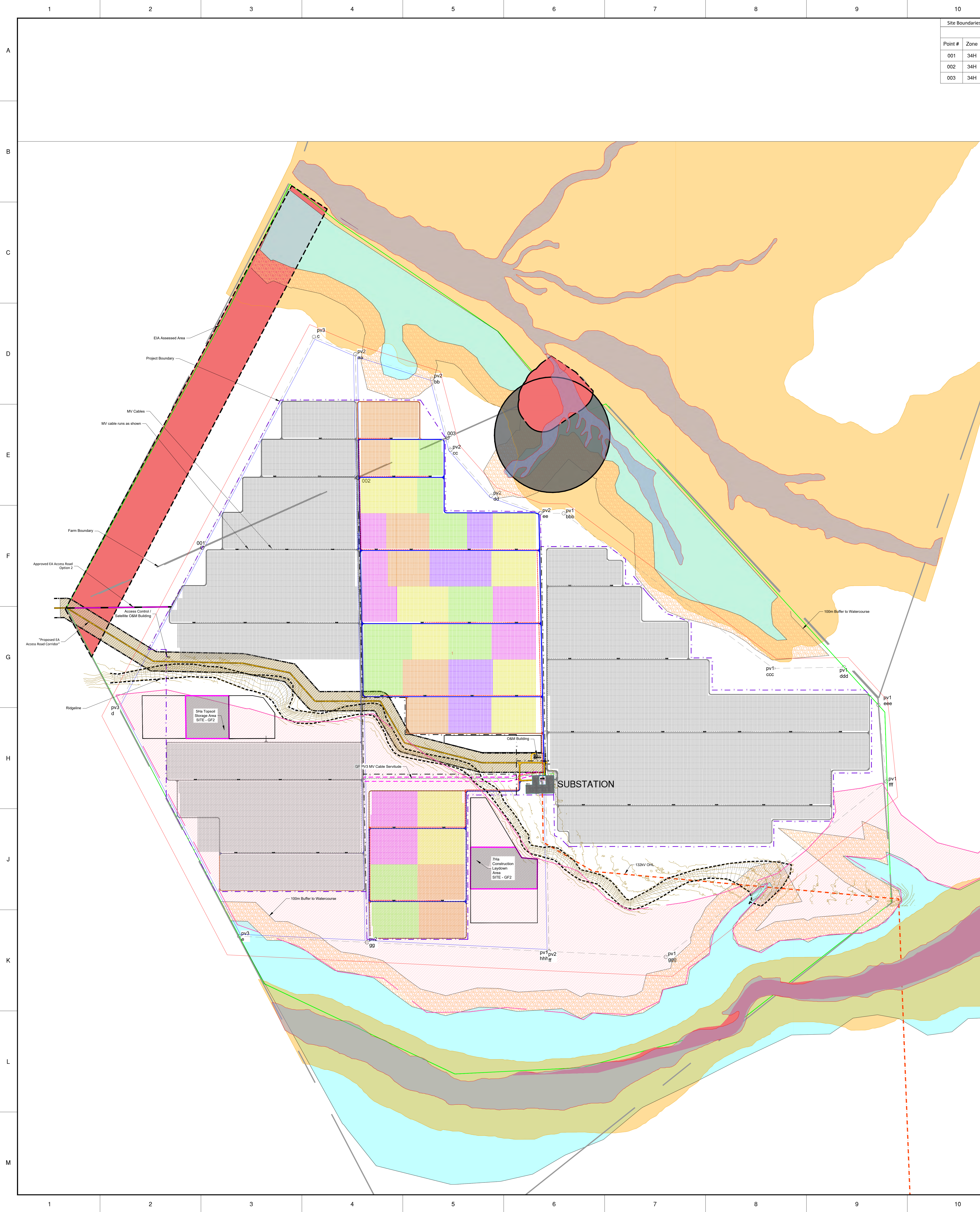

DRAFT

Rev	Date	QA/QC	Description	Drawn	Eng
00	18/02/2022	X	DRAFT - ISSUED FOR APPROVAL	M.c.A	P.vWyk



1 Dock Road, 2nd Floor, North Block
Waterway House, V&A Waterfront
Cape Town
8005

www.scatec.com

Project: **GROOTFONTEIN PV 2**

Title: **ENVIRONMENTAL AUTHORIZATION
SITE GF-02
APPROVAL LAYOUT**

Drawing no: **SCA-EN-DWG-EA201**

Draughtsman: M.c.ADAMS	Engineer: P.Van Wyk	Approved: -
Size: A0	Scale: 1:7500	Sheet Number: -

Copyright: Scatec