

# Proposed development of Portion 209 of Farm 220 Vyf Brakke Fontein, Aalwyndal, Mossel Bay

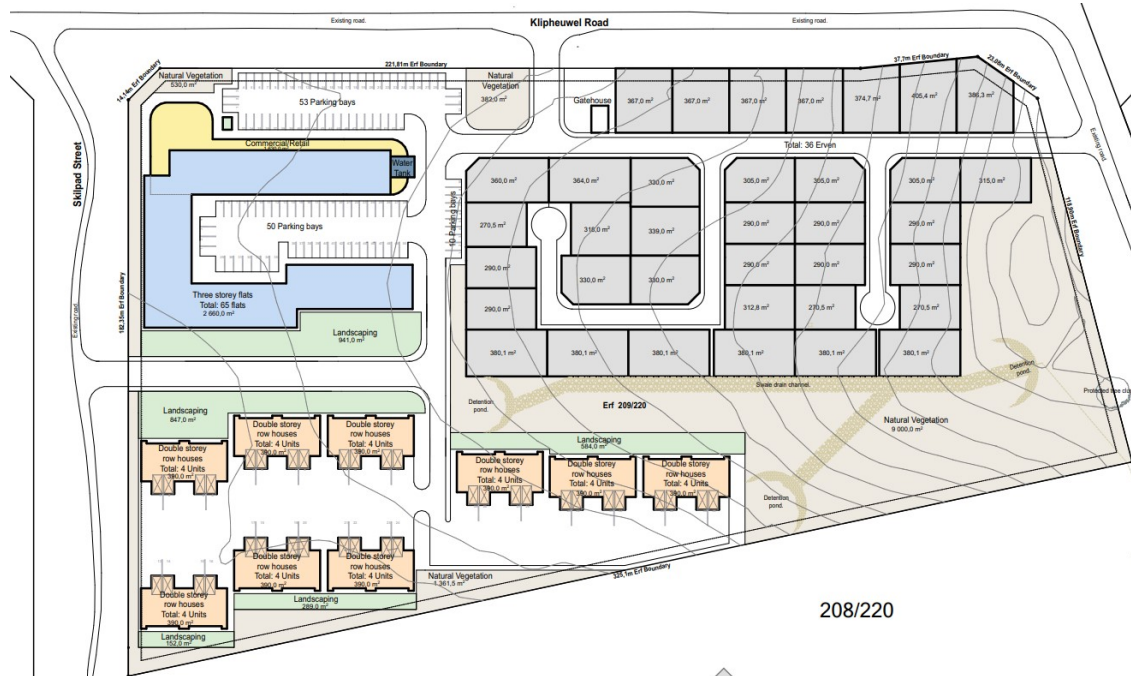

## Stormwater Management Plan

Revision 1

July 2024

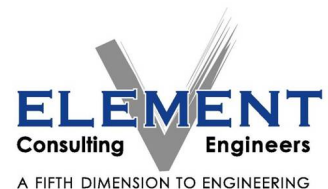

**George Office**  
Western Cape

Tel: +27 44 884 1138

Fax: +27 44 884 1185

82 Victoria Street, George, 6529

PO Box 9962, George, 6530

[www.eceng.co.za](http://www.eceng.co.za)

**Proposed development of  
Portion 209 of Farm 220 Vyf Brakke Fontein,  
Aalwyndal, Mossel Bay**

**Stormwater Management Plan**

**Revision 1**

**July 2024**

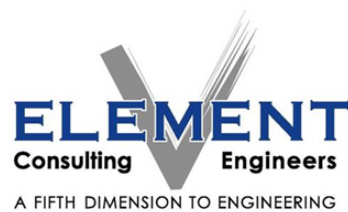

PREPARED FOR:

PREPARED BY:

Element Consulting Engineers  
82 Victoria Street  
PO Box 9962  
George  
6530

Tel: +27 44 884 1138

# DOCUMENT CONTROL SHEET

<b>Compiled By:</b>	..... Hannes Lourens PrEng MEng	..... Date
<b>Reviewed By:</b>	..... Hannes Lourens PrEng MEng	..... Date

Revision	Description	Date Issued	Revision By:
0	Report	May 2023	HL
1	Updated stormwater layout plan	July 2024	HL

## DISTRIBUTION LIST

Name	Company	Email	Tel

**Proposed development of  
Portion 209 of Farm 220 Vyf Brakke Fontein,  
Aalwyndal, Mossel Bay**

**Stormwater Management Plan**

**Revision 1**

**CONTENTS**

---

<b>Chapter</b>	<b>Description</b>	<b>Page</b>
<b>1</b>	<b>INTRODUCTION AND BACKGROUND</b>	<b>3</b>
<b>2</b>	<b>SITE DEVELOPMENT PLAN</b>	<b>4</b>
<b>3</b>	<b>LOCALITY AND ACCESS</b>	<b>5</b>
<b>4</b>	<b>GEOTECHNICAL INVESTIGATION</b>	<b>7</b>
<b>5</b>	<b>STORMWATER MANAGEMENT PLAN</b>	<b>9</b>
	5.1 Design background	9
	5.2 Environmental design considerations	9
	5.3 Freshwater habitat compliance statement recommendations	10
	5.3.1 Introduction	10
	5.3.2 Evidence of wetland, drainage line or watercourse	11
	5.3.3 External drainage lines	12
	5.3.4 Watercourse classification	12
	5.3.5 Conclusion	13
	5.4 General freshwater habitat stormwater specifications	13
	5.4.1 Freshwater habitat stormwater design guidelines	14
	5.4.2 Post-construction rehabilitation phase	15
	5.4.3 Operational Phase	15
	5.5 Technical stormwater design	15
	5.6 Site layout considerations	16
	5.7 Stormwater design	17
	5.7.1 Drainage zone A	18
	5.7.2 External (east) of zone A	20
	5.7.3 Drainage zone B	24
	5.7.4 Drainage zone C	24
	5.7.5 Swale drain	24
	5.7.6 Energy dissipation	25
	5.7.7 Stormwater design drawings	25

	5.8	Internal streets	27
<b>6</b>		<b>CONCLUSIONS AND RECOMMENDATIONS</b>	<b>28</b>
	6.1	Conclusions	28
	6.2	Recommendations	35
<b>7</b>		<b>ADDENDA</b>	<b>36</b>
	7.1	Addendum 1 – Site development plans	36
	7.2	Addendum 2 – Stormwater management plan drawings & typical details	36

# **1 INTRODUCTION AND BACKGROUND**

---

Element Consulting Engineers has been appointed for the compilation of a stormwater management plan for the proposed development of Portion 209 of the Farm 220 Vyf Brakke Fontein, Aalwyndal, Mossel Bay.

The project proposes the development of a 1,630m<sup>2</sup> commercial area, 65 apartments, 36 townhouses and 37 group housing units.

This report will detail and discuss the stormwater management plan for the development in terms of the internal engineering designs, engineering standards, technical design criteria and environmental issues applicable to the project.



### 3 LOCALITY AND ACCESS

---

The proposed development is located on Portion 209 of the Farm 220 Vyf Brakke Fontein, Aalwyndal, Mossel Bay. The site is bordered to the north and east by Klipheuwel Road and to the west by Skilpad Street. The site is bordered to the south by Portion 208.

Locality of the proposed project is presented in the diagram below.



*Figure 2: Locality*

Proposed access to the development is obtained via Klipheuwel Road from the north and east and from Skilpad Street from the west. These proposed access points are indicated in the diagram below.

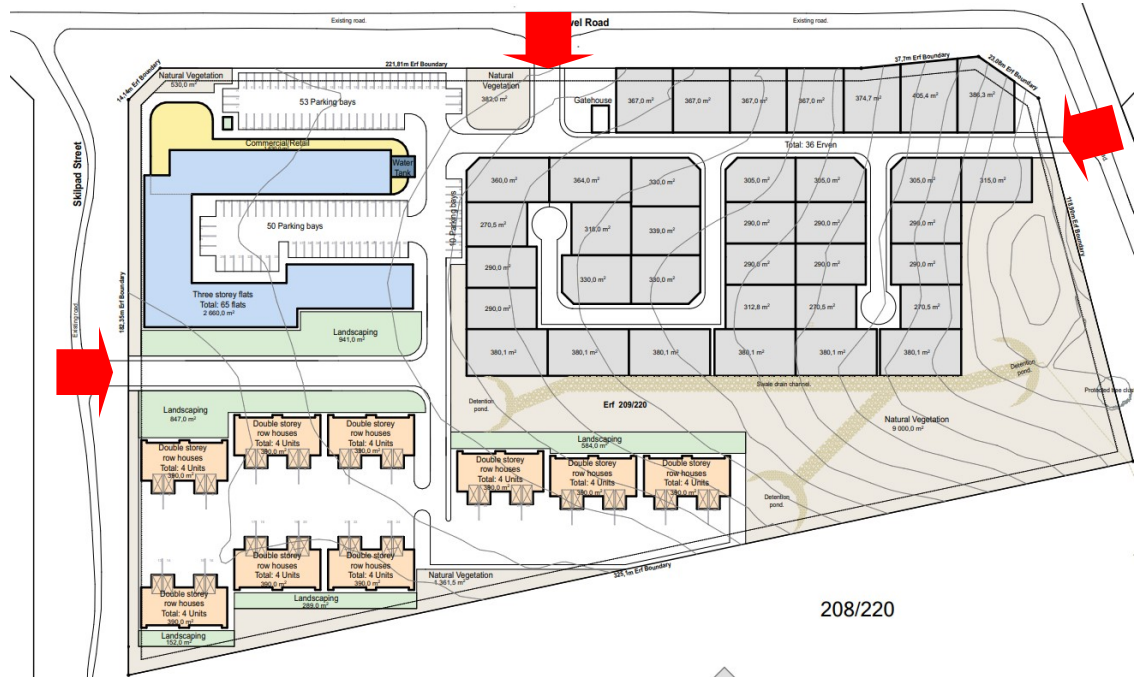

Figure 3: Proposed access to the development

## 4 GEOTECHNICAL INVESTIGATION

---

A formal geotechnical investigation has not been performed. Various visual inspections of the site were conducted in order to assess conditions on site.

The holistic conclusion is reached that the in-situ materials found on site are adequate for the construction of engineering services and foundations for low-level residential and commercial development.

### **Topography**

The site is characterized by gentle sloping topography generally to the east.

### **Drainage**

The study area is drained by means of surface run-off (i.e.: sheetwash), with storm water following the topography of the site to the east.

### **Rock outcrops**

Rock outcrops were not visually encountered within the investigated area although the area is known for shallow rock.

### **Groundwater seepage**

No groundwater or seepage were evident on the site. The site was generally dry. Groundwater levels are not expected to be shallow.

### **General soil profile**

The site is covered by a relatively homogeneous light brown silty sandy material. The material is loose and dry. This covering material is expected to be underlain by shallow rock of varying depth.

### **Bearing capacity**

From a visual investigation, the material on site will be adequate for the construction of engineering services and foundations for low-level residential and commercial development. The material on site is visually able to carry a minimum allowable bearing capacity of 150 kPa.

### **Slope stability**

Existing gentle slopes appear to be generally stable.

### **Drainage**

An efficient surface drainage system shall be installed throughout the development, around all structures and along all roads.

## **5 STORMWATER MANAGEMENT PLAN**

---

This chapter will discuss the stormwater management plan of the proposed development in terms of the internal engineering designs in parallel with the engineering standards and technical design criteria applicable to the project.

### **5.1 Design background**

Stormwater technical design on this development is relatively uncomplicated due to the development being situated on top of a watershed. Stormwater from the watershed drains generally to the east. Due to the aforementioned, i.e. the development being situated on top of a watershed, stormwater is hence relatively unconcentrated in the relatively small accumulation areas forming the development footprint. From an environmental perspective, nevertheless, stormwater release into the natural drainage lines and natural vegetation needs to be addressed thoroughly.

### **5.2 Environmental design considerations**

Stormwater design on this proposed development is notable not only from an engineering perspective but also from an environmental perspective due to the natural drainage lines and natural vegetation present in the area.

Environmental design shall make use of Sustainable Drainage Systems (SuDs) to manage stormwater within and outside of the development footprint. SuDs will assist in preventing significant impact on the hydrological functioning of the natural drainage lines, reduce the risk of flooding and reduce the risk of erosion. SuDs vegetated with indigenous species can assist with water polishing, trapping hydrocarbons from stormwater runoff from the development area before this is released into the natural drainage lines.

Energy dissipation shall be performed as standard practice with gabion mattresses at all outlets. All pipe outlets shall be standard concrete headwalls. Litter traps shall be provided at all stormwater outlets and shall be cleaned on a regular basis by the development's landscaping and maintenance teams.

Mini-attenuation ponds shall be provided at each outlet to allow particles to settle. Indigenous vegetation shall be established within the mini-attenuation ponds. Outlets from the mini attenuation ponds shall be designed as swales into the drainage zones. Swales shall also be utilized in upstream areas of the development wherever possible. Materials with high roughness shall be utilized within swales in order to further assist with energy dissipation. This will further prevent erosion and improve habitat provision.

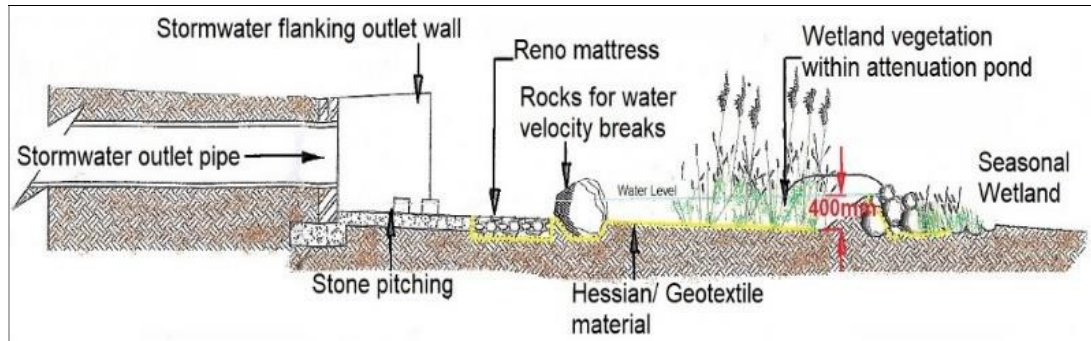

Figure 4: Mini-attenuation ponds at headwall outlets



Figure 5: Example of swales

### 5.3 Freshwater habitat compliance statement recommendations

The freshwater habitat compliance statement (FHCS) by Confluent Environmental (Confluent) (March 2022) was studied as input into this stormwater management report. Relevant extracts from the FHCS report are discussed in this chapter and, where relevant, imported into the stormwater management plan.

#### 5.3.1 Introduction

The mitigation of negative impacts on biodiversity and ecosystems is a legal requirement. Its application is intended to strive to first avoid disturbance of ecosystems and loss of

biodiversity, and where this cannot be avoided altogether, to minimize, rehabilitate, and finally offset any remaining significant residual negative impacts on biodiversity.

Any potential risks must be managed and mitigated to ensure that no deterioration to the water resource takes place. Management measures should be implemented to ensure that no activities result in a decline in water resource quality.

The monitoring of the development activities is essential to ensure the mitigation measures are implemented and compliance with the mitigation recommendations must be audited by an Environmental Control Officer (ECO). Monitoring for compliance must be done on a daily basis by the contractors. Photographic records of all incidents and non-compliances must be retained. Monitoring should especially focus on preventing water pollution, avoiding riparian habitat, and determining the success of the stormwater management plan.

### **5.3.2 Evidence of wetland, drainage line or watercourse**

The entire site was inspected for evidence of a wetland, drainage line, or any other watercourse. The area is in a natural state, being densely vegetated by a variety of fynbos species.

The site itself is positioned on a plateau with very low topography. As it is almost flat with no catchment, there is little opportunity for significant runoff to accumulate or flow paths to form.



*Figure 6: Natural fynbos vegetation on Vyf Brakke Fontein 209/220*

A small culvert to the east of the proposed development site indicates a small volume of water potentially runs off the site at this point, but no channel or flow path could be identified.

### **5.3.3 External drainage lines**

Watercourses and drainage lines in a 500m radius of the development were inspected. These included a drainage line to the north-east of the proposed development and a drainage line to the south of the proposed development.

The two abovementioned watercourses in the vicinity of the development had well defined riparian vegetation in comparison to the terrestrial vegetation on the proposed development site.

### **5.3.4 Watercourse classification**

Watercourses external to the development are in steep valleys draining from the upland areas towards the sea. Vegetation along all the two external watercourses inspected was typical of riparian vegetation along intermittent drainage lines. All watercourses had typically steep, deeply incised channels making access difficult. Dominant vegetation consists of alien vegetation along with indigenous species. Whilst the streamside vegetation had a more robust growth form than surrounding terrestrial vegetation, it did not contain typical wetland vegetation species.

Therefore, watercourses within 500 m of the proposed development site are classified as drainage lines with intermittent flows. This is in contradiction to the mapped classification of parts of watercourses which were mapped as wetlands in the NWM5 spatial layer but was confirmed during the site visit.

### **5.3.5 Conclusion**

Based on the results of the report, the sensitivity of aquatic biodiversity on Portion 209/220 can be regarded as Low. The main factors influencing the statement include the following:

- While the development is located in a FEPA, the specific development site has no watercourses within the footprint of the road or housing area;
- Freshwater features identified within 500 m of the site were classified as drainage lines and are unlikely to be impacted by the development in any way.

The proposed housing development and possible road upgrade would take place more than 32 m from the edge of watercourses, and outside of the riparian zone of watercourses. No triggered listed activities or water uses are therefore anticipated in terms of the NEMA or NWA respectively.

In line with the above conclusions, no watercourses, riparian zones or aquatic buffer zone will impact on the proposed development and will be incorporated as such into the stormwater management plan.

## **5.4 General freshwater habitat stormwater specifications**

Aquatic buffer zones are provided to act as barriers between human activities and sensitive water resources in order to protect them from adverse negative impacts. Buffer zones associated with water resources have been shown to perform a wide range of functions and have therefore been adopted as a standard measure to protect water resources and associated biodiversity. An aquatic buffer zone is defined as a zone of vegetated land designed and managed so that sediment and pollutant transport carried from source areas via diffuse surface runoff is reduced to acceptable levels.

Buffer zones must be demarcated during construction and no disturbance may occur in this area. All engineering and other infrastructure, inclusive of but not limited to stormwater attenuation, sewage lines, water lines, roads and pathways must lie outside of this setback area. All of the above must be accounted for in the design layout and construction methodology of the contractor.

Mitigation of impacts should focus on managing the runoff generated by the development and introducing it responsibly into the receiving environment. The stormwater flows must enter the buffer and riparian areas in a diffuse flow pattern without pollutants.

#### **5.4.1 Freshwater habitat stormwater design guidelines**

Designs must provide due consideration to the collection and treatment of stormwater, prior to discharge into the natural environment. Designs must provide due consideration to the appropriate ecological input and be based on Sustainable Drainage Systems (SuDs). Permeable infrastructure must be considered where practical. This may include items such as permeable concrete block pavers, permeable brick pavers, stone and gravel. Soft and porous infiltration channels or -basins must be provided where necessary and shall contribute to slowing surface flows. This may include a.o. swales and gabion mattresses. Gradients of swales and gabion mattress channels to be designed as flat as possible. This will provide filtration, removal of urban pollutants (e.g. hydrocarbons), provide attenuation, and dissipate energy of storm water flows through increased roughness (compared to pipes and concrete V-drains).



*Figure 7: Example of soft infrastructure incorporated into the stormwater design*

Stormwater outlets must be provided as frequently as possible in order to reduce accumulation as far as possible and hence to prevent erosion at discharge points as far as possible. Erosion protection measures (e.g. gabion-mattresses) must be established to reflect the natural slope of the surface and located at the natural ground level. Stormwater infrastructure, such as gabion mattresses at pipe outlets, must be located within the development footprint and not encroach into the buffer area.

Stormwater outlets must trap any additional suspended solids and pollutants originating from the development.

Stockpiles shall not be placed in vegetated areas that will not be cleared as part of the development. Erosion control measures including silt fences, low soil berms and/or shutter boards must be put in place around the stockpiles to limit sediment runoff from stockpiles.

#### **5.4.2 Post-construction rehabilitation phase**

Post construction rehabilitation activities to all disturbed areas shall include the following:

- The area must be maintained through alien invasive plant species removal and the establishment of indigenous vegetation cover to filter run-off before it exists the site.
- The solid domestic waste must be removed and disposed of offsite. All post-construction building material and waste must be cleared and disposed of in a suitable manner and areas rehabilitated.
- Removal of vegetation must only occur where required for the project and disturbance to the adjoining natural vegetation cover or soils is not allowed.
- Erosion features that have developed are to be stabilized.
- A monitoring programme shall be in place, not only to ensure compliance with the EMP throughout the construction phase, but also to monitor any post-construction environmental issues and impacts such as increased surface runoff.
- All disturbed areas shall be rehabilitated and maintained.

#### **5.4.3 Operational Phase**

Any evidence of erosion from the stormwater system must be rehabilitated and the volume/velocity of the water reduced through further structures and/or energy dissipaters. These structures must be incorporated within the layout area.

### **5.5 Technical stormwater design**

A formal stormwater reticulation system will be required and shall be provided by a combination of surfaced roadways, kerbs, channels, cut-off drains, stormwater pipes and various minor structures. The integrated stormwater and road system form an integral part of layout planning. The system rests on three legs, namely the minor system, the major system and the emergency system. Minor storms and normal flow-off are catered for in the normal road prism and piped system. Major storms are routed through a linked system of road prisms and public open spaces, using attenuation techniques. The emergency system recognizes failure of the minor and major systems and provides for

emergency runoff by providing continuous overland flow routes to minimize flooding of residential areas.

The following standards and design criteria are specified:

- Minor system designed for 2-year return period and conveyed in a combination of maximum 200m aboveground in the road prism and underground piped system.
- Major system designed for 50-year return period. Difference between the 50 year and 2-year flood to be conveyed in the road prism with depths not exceeding 150mm and into designated public open spaces, using attenuation techniques.
- Minimum gradients for pipelines to allow minimum flow speeds of 0.7m/s at full flow.
- Maximum pipeline flow velocities to be 3.5m/s.
- Stormwater pipes to be 100D as required by specific loadings or installation conditions.
- Bedding to be Class C.
- Minimum cover on pipes to be 800mm.
- Minimum pipe diameter to be 450mm.
- Gravel traps to be provided in structures (where required on steeper slopes).
- Gabion (reno) mattresses to be provided at all outlets for energy dissipation and erosion protection.
- Litter traps to be provided at all outlets.
- Outlets to be standard concrete headwalls.
- Mini-attenuation ponds to be provided at all outlets.
- Outlets from mini attenuation ponds to be designed as swales.
- All stormwater structures on the project to be non-erosive, structurally stable and shall not induce any flooding or safety hazard.
- All stormwater systems and structures to be designed by a professional engineer.
- All stormwater infrastructure and structures to be inspected and cleaned on a regular basis by the landscaping and maintenance teams.
- All stormwater infrastructure to be designed on SuDs principles.
- Soft and porous infiltration channels or -basins to be provided where possible.
- Stormwater outlets to be provided as frequently as possible in order to reduce accumulation and concentration as far as possible.

Also refer to typical detail drawings attached to the report as addendum.

## **5.6 Site layout considerations**

Stormwater technical design on this development is relatively uncomplicated due to the development being situated on top of a triple watershed. Due to the aforementioned,

stormwater is hence relatively unconcentrated in the relatively small accumulation areas forming the development footprint.

Three drainage zones are identified for design and report purposes and are as follows:

- Zone A: Approximately 93% of the site drains towards a general eastern direction towards Voorbaai and is designated as Zone A.
- Zone B: Approximately 3% of the site drains towards a general northern direction and is designated as Zone B.
- Zone C: Approximately 4% of the site drains towards a general southern direction and is designated as Zone C.

The designated drainage zones as identified above are indicated diagrammatically on the figure below:



Figure 8: Stormwater drainage zones

## 5.7 Stormwater design

Stormwater technical design on this development is relatively uncomplicated due to the development being situated on top of a triple watershed. The technical stormwater design on the project is however still important to consider as part of the stormwater management plan.

The internal stormwater design zones, as discussed in the previous section, are indicated in the following stormwater design drawing.

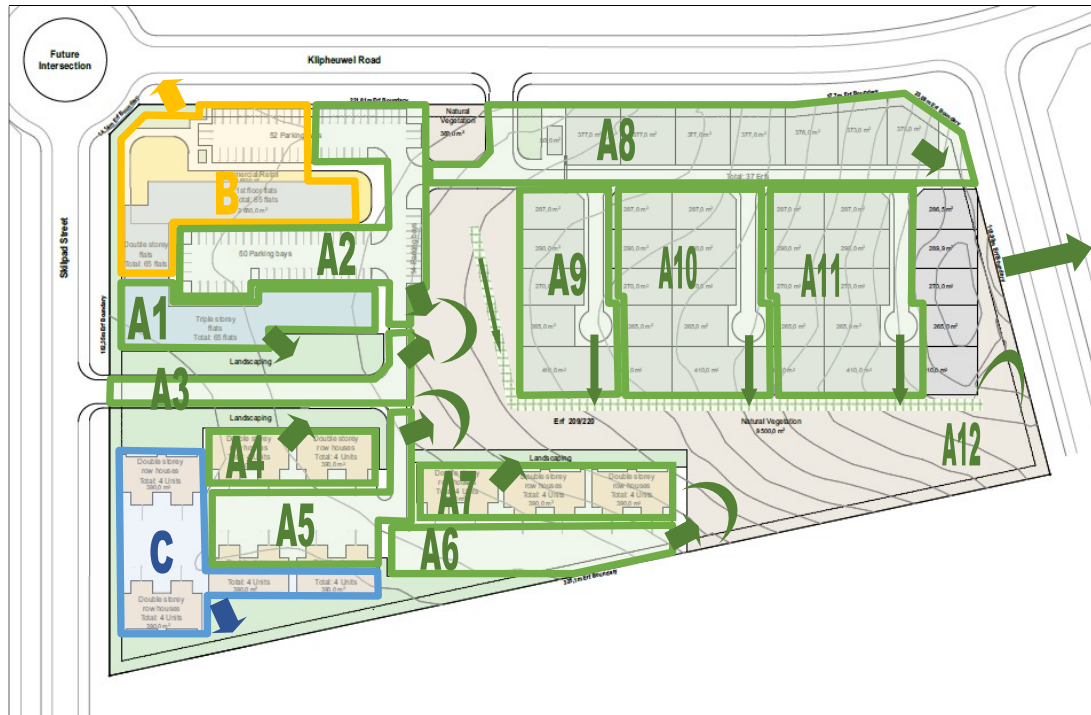

Figure 9: Internal stormwater design zones.

### 5.7.1 Drainage zone A

Approximately 93% of the site drains towards a general eastern direction towards Voorbaai. This area is designated as Zone A and is divided into a number of sub-drainage zones in accordance with the SDP layout planning:

#### Drainage zone A1

Zone A1 has an area of approximately 0.06ha with an estimated 1:2 year peak flow of 0.003m<sup>3</sup>/s and 1:50 year peak flow of 0.009m<sup>3</sup>/s and shall be routed from the apartment roofs into the landscaping area.

#### Drainage zone A2

Zone A2 has an area of approximately 0.17ha with an estimated 1:2 year peak flow of 0.009m<sup>3</sup>/s and 1:50 year peak flow of 0.026m<sup>3</sup>/s and shall be routed via a formal stormwater system into a proposed internal detention pond of approximately 34m<sup>3</sup> in volume. The detention pond shall be a focus point in the development with ample landscaping and beautification. The outlet from this internal detention pond shall trickle into the swale drain as indicated.

### **Drainage zone A3**

Zone A3 has an area of approximately 0.03ha with an estimated 1:2 year peak flow of 0.002m<sup>3</sup>/s and 1:50 year peak flow of 0.005m<sup>3</sup>/s and shall be routed via a formal stormwater system into a proposed internal detention pond together with Zone A2.

### **Drainage zone A4**

Zone A4 has an area of approximately 0.05ha with an estimated 1:2 year peak flow of 0.003m<sup>3</sup>/s and 1:50 year peak flow of 0.008m<sup>3</sup>/s and shall be routed from the apartment roofs into the landscaping area.

### **Drainage zone A5**

Zone A5 has an area of approximately 0.1ha with an estimated 1:2 year peak flow of 0.005m<sup>3</sup>/s and 1:50 year peak flow of 0.015m<sup>3</sup>/s and shall be routed via a formal stormwater system into a proposed internal detention pond of approximately 17m<sup>3</sup> in volume. The detention pond shall be a focus point in the development with ample landscaping and beautification. The outlet from this internal detention pond shall trickle into the swale drain as indicated.

### **Drainage zone A6**

Zone A6 has an area of approximately 0.09ha with an estimated 1:2 year peak flow of 0.005m<sup>3</sup>/s and 1:50 year peak flow of 0.014m<sup>3</sup>/s and shall be routed via a formal stormwater system into a proposed internal detention pond of approximately 16m<sup>3</sup> in volume. The detention pond shall be a focus point in the development with ample landscaping and beautification. The outlet from this internal detention pond shall trickle into the swale drain as indicated.

### **Drainage zone A7**

Zone A7 has an area of approximately 0.06ha with an estimated 1:2 year peak flow of 0.003m<sup>3</sup>/s and 1:50 year peak flow of 0.009m<sup>3</sup>/s and shall be routed from the apartment roofs into the landscaping area.

### **Drainage zone A8**

Zone A8 has an area of approximately 0.34ha with an estimated 1:2 year peak flow of 0.018m<sup>3</sup>/s and 1:50 year peak flow of 0.052m<sup>3</sup>/s. Zone A8 will drain into the municipal culvert underneath Klipheuwel Road.

### **Drainage zone A9**

Zone A9 has an area of approximately 0.17ha with an estimated 1:2 year peak flow of 0.009m<sup>3</sup>/s and 1:50 year peak flow of 0.026m<sup>3</sup>/s and shall be routed via a formal stormwater system via a proposed stormwater servitude into the swale drain as indicated.

### **Drainage zone A10**

Zone A10 has an area of approximately 0.31ha with an estimated 1:2 year peak flow of 0.017m<sup>3</sup>/s and 1:50 year peak flow of 0.047m<sup>3</sup>/s and shall be routed via a formal stormwater system via a proposed stormwater servitude into the swale drain as indicated.

### **Drainage zone A11**

Zone A11 has an area of approximately 0.31ha with an estimated 1:2 year peak flow of 0.017m<sup>3</sup>/s and 1:50 year peak flow of 0.047m<sup>3</sup>/s and shall be routed via a formal stormwater system via a proposed stormwater servitude into the swale drain as indicated.

### **Drainage zone A12**

Zone A12 has an area of approximately 0.55ha with an estimated 1:2 year peak flow of 0.030m<sup>3</sup>/s and 1:50 year peak flow of 0.084m<sup>3</sup>/s and shall be routed via a formal stormwater system into a proposed internal detention pond of approximately 95m<sup>3</sup> in volume. The detention pond shall be a focus point in the development with ample landscaping and beautification. The outlet from this internal detention pond will drain into the municipal road reserve.

## **5.7.2 External (east) of zone A**

Stormwater external (east) of drainage zone A currently drains into a culvert underneath Klipheuwel Road and continues east along the drainage line over Portion 206. Three options were explored for the stormwater management from this position in Klipheuwel Road. These options are depicted on the diagram below and is discussed in the following paragraphs. A final decision shall be negotiated and included into the services agreement with the municipality.

### **Option 1: South**

Option 1 shall take a route directly south in the road reserve of Klipheuwel Road and along the boundary of Portion 208 along the 2m building line, i.e. 1m from the erf

boundary, and discard stormwater directly into the drainage line to the south. The total length of this option is 147m and shall be a 600mm concrete stormwater line. This option cuts slightly through the watershed to the south and hence will be approximately 3m deep at its deepest portion. The option is technically feasible.

### Option 2: North-East

Option 2 shall take a route north in the road reserve of Klipheuwel Road, then east along the alignment of the proposed Henning Road extension, and finally south along the eastern border of Portion 206 into the drainage line. This route effectively runs around Portion 206 through which the natural drainage line runs. The total length of this option is 378m and shall be a 600mm concrete stormwater line. The vertical alignment of this route will follow a continuous downward slope. This option, although technically feasible, is the most expensive alternative.

### Option 3: East

Option 3 shall take the direct route east along the drainage line over Portion 206. This option will entail a municipal services (stormwater) servitude over Portion 206 to be registered. The total length of this option is 237m and shall be an open stormwater channel. This option is the most technically feasible and cost effective, but will however entail buying out a municipal stormwater servitude from the owner of Portion 206.



Figure 10: Three external stormwater options on eastern boundary.



*Figure 11: Culvert on eastern boundary underneath Klipheuwel Road.*



*Figure 12: Culvert on eastern boundary underneath Klipheuwel Road.*



*Figure 13: Culvert on the eastern boundary of the site underneath Klipheuwel Road*



*Figure 14: Drainage line to the north-east of the proposed development*



*Figure 15: Drainage line to the south of the proposed development*

### **5.7.3 Drainage zone B**

Approximately 3% of the site drains towards a general northern direction. This area is designated as Zone B and has an area of approximately 0.14ha with an estimated 1:2 year peak flow of 0.007m<sup>3</sup>/s and 1:50 year peak flow of 0.021m<sup>3</sup>/s. Stormwater drainage at this northern corner of the development shall be discharged into Klipheuwel Road road reserve form where it shall drain naturally to the north. Energy dissipation shall be performed at this outlet with a gabion cascade and mattress design and water shall be dispersed as widely as possible.

### **5.7.4 Drainage zone C**

Approximately 4% of the site drains towards a general southern direction. This area is designated as Zone C and has an area of approximately 0.15ha with an estimated 1:2 year peak flow of 0.008m<sup>3</sup>/s and 1:50 year peak flow of 0.023m<sup>3</sup>/s. Stormwater drainage at this southern corner of the development shall be discharged into the adjacent property. Energy dissipation shall be performed at this outlet with a gabion cascade and mattress design and water shall be dispersed as widely as possible.

### **5.7.5 Swale drain**

The swale drain running through the development from west to east shall be constructed as a porous infiltration channel with a rock or similar layer which will contribute to slowing

surface flows. The swale drain shall be designed and constructed with frequent energy dissipators in the form of gabion boxes, simultaneously also vertical drops. The swale drain shall have a slope of 1% between energy dissipators in order to maximize energy dissipation and infiltration into the subsurface. This will provide filtration, removal of urban pollutants (e.g. hydrocarbons), provide attenuation, and dissipate energy of storm water flows through increased roughness (compared to pipes and concrete V-drains). The swale drain shall simultaneously be designed to be a focus point with ample landscaping and beautification.

### 5.7.6 Energy dissipation

Energy dissipation shall be performed at all outlets with a gabion cascade and gabion mattress design. Water shall simultaneously be dispersed to the maximum at all outlets.

### 5.7.7 Stormwater design drawings

The drawing below presents the stormwater design of the proposed development and is also attached as addendum.

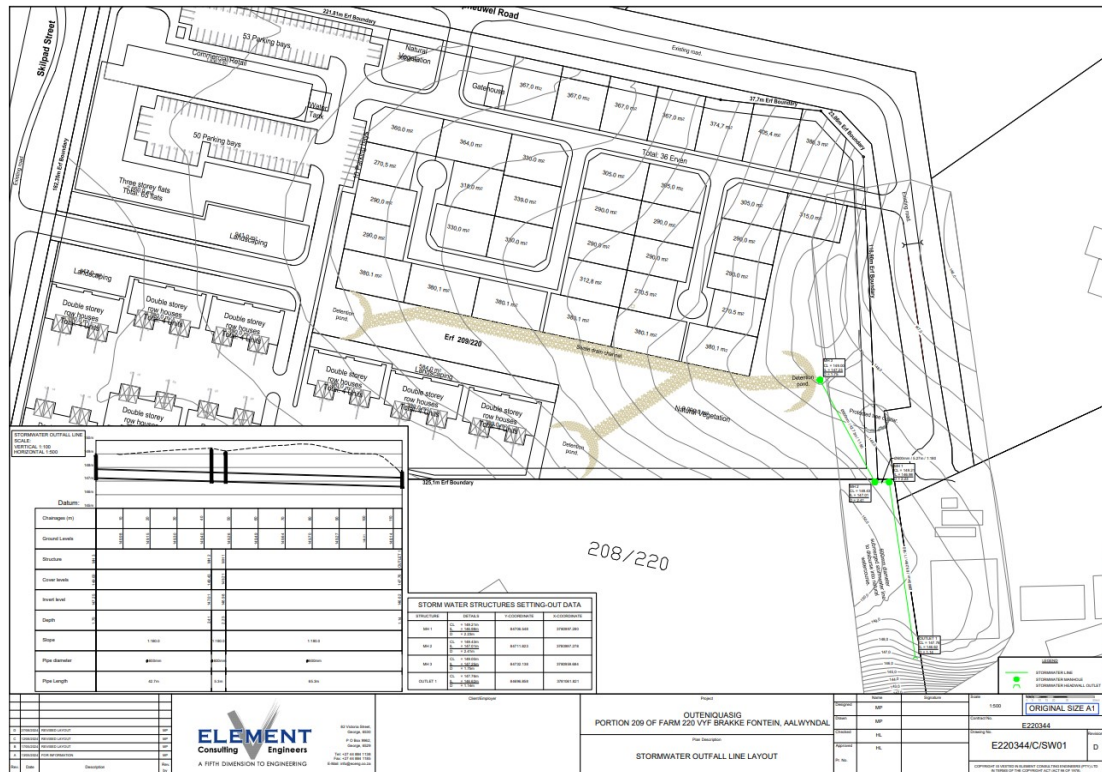

Figure 16: Stormwater design drawing.

Stormwater design typical details are indicated in the following design drawings and are also attached as addenda.



## **5.8 Internal streets**

Internal design of streets is intertwined with stormwater design and from an engineering perspective, streets are considered a part of stormwater design. Internal standards and design criteria for internal street design, relevant to the stormwater management plan, are specified as follows:

- Internal road widths of between 5.2m and 7.4m, depending on road class.
- Asphalt surfacing 30mm on all internal streets, alternatively interlocking paving 80mm on all internal streets.
- Minimum road grade of 0.4% and camber or crossfall of 2%.
- Kerbing to be a combination of CK5, MK10, Fig4 and C1 kerbs.
- Integrated kerb inlet structures to be provided on suitable intervals.

## 6 CONCLUSIONS AND RECOMMENDATIONS

---

### 6.1 Conclusions

The following conclusions can be reached from the Stormwater Management Plan of the proposed development of Portion 209 of the Farm 220 Vyf Brakke Fontein, Aalwyndal, Mossel Bay:

1. Stormwater technical design on this development is relatively uncomplicated due to the development being situated on top of a watershed. Stormwater from the watershed drains generally to the east. Stormwater is hence relatively unconcentrated in the relatively small accumulation areas forming the development footprint. From an environmental perspective, nevertheless, stormwater release into the natural drainage lines and natural vegetation needs to be addressed thoroughly.
2. Stormwater design on this proposed development is notable not only from an engineering perspective but also from an environmental perspective due to the natural drainage lines and natural vegetation present in the area.
3. Environmental design shall make use of Sustainable Drainage Systems (SuDs) to manage stormwater within and outside of the development footprint. SuDs will assist in preventing significant impact on the hydrological functioning of the natural drainage lines, reduce the risk of flooding and reduce the risk of erosion. SuDs vegetated with indigenous species can assist with water polishing, trapping hydrocarbons from stormwater runoff from the development area before this is released into the natural drainage lines.
4. Energy dissipation shall be performed as standard practice with gabion mattresses at all outlets. All pipe outlets shall be standard concrete headwalls. Litter traps shall be provided at all stormwater outlets and shall be cleaned on a regular basis by the development's landscaping and maintenance teams. Mini-attenuation ponds shall be provided at each outlet to allow particles to settle. Indigenous vegetation shall be established within the mini-attenuation ponds. Outlets from the mini attenuation ponds shall be designed as swales into the drainage zones. Swales shall also be utilized in upstream areas of the development wherever possible. Materials with high roughness shall be utilized within swales in order to further assist with energy dissipation. This will further prevent erosion and improve habitat provision.
5. Based on the results of the freshwater habitat report, the sensitivity of aquatic biodiversity on Portion 209/220 can be regarded as low. The main factors influencing this conclusion are firstly that the specific development site has no watercourses within the development footprint and secondly that freshwater

features identified within 500 m of the site (external) were classified as drainage lines and are unlikely to be impacted by the development. The proposed development would take place more than 32 m from the edge of watercourses, and outside of the riparian zone of watercourses. No triggered listed activities or water uses are therefore anticipated in terms of the NEMA or NWA respectively. It is concluded that no watercourses, riparian zones or aquatic buffer zone will impact on the proposed development.

6. From a general freshwater habitat perspective, the following design considerations shall be entertained:
  - a. Stormwater designs must provide due consideration to the collection and treatment of stormwater, prior to discharge into the natural environment.
  - b. Designs must provide due consideration to the appropriate ecological input and be based on Sustainable Drainage Systems (SuDs). Permeable infrastructure must be considered where practical. This may include items such as permeable concrete block pavers, permeable brick pavers, stone and gravel. Soft and porous infiltration channels or -basins must be provided where necessary and will contribute to slowing surface flows. This may include a.o. swales and gabion mattresses. Gradients of swales and gabion mattress channels to be designed as flat as possible. This will provide filtration, removal of urban pollutants (e.g. hydrocarbons), provide attenuation, and dissipate energy of storm water flows through increased roughness (compared to pipes and concrete V-drains).
  - c. Stormwater outlets must be provided as frequently as possible in order to reduce accumulation as far as possible and hence to prevent erosion at discharge points as far as possible. Erosion protection measures (e.g. gabion-mattresses) must be established to reflect the natural slope of the surface and located at the natural ground level. Stormwater infrastructure, such as gabion mattresses at pipe outlets, must be located within the development footprint.
  - d. Stormwater outlets must trap any additional suspended solids and pollutants originating from the development.
  - e. Stockpiles shall not be placed in vegetated areas that will not be cleared as part of the development. Erosion control measures including silt fences, low soil berms and/or shutter boards must be put in place around the stockpiles to limit sediment runoff from stockpiles.
  - f. Post construction rehabilitation activities to all disturbed areas shall include the following:
    - i. The area must be maintained through alien invasive plant species removal and the establishment of indigenous vegetation cover to filter run-off before it exists the site.
    - ii. The solid domestic waste must be removed and disposed of offsite. All post-construction building material and waste must be

- cleared and disposed of in a suitable manner and areas rehabilitated.
- iii. Removal of vegetation must only occur where required for the project and disturbance to the adjoining natural vegetation cover or soils is not allowed.
  - iv. Erosion features that have developed are to be stabilized.
  - v. A monitoring programme shall be in place, not only to ensure compliance with the EMP throughout the construction phase, but also to monitor any post-construction environmental issues and impacts such as increased surface runoff.
  - vi. All disturbed areas shall be rehabilitated and maintained.
7. A formal stormwater reticulation system shall be required and shall be provided by a combination of surfaced roadways, kerbs, channels, cut-off drains, stormwater pipes and various minor structures. The integrated stormwater and road system form an integral part of layout planning. The system rests on three legs, namely the minor system, the major system and the emergency system. Minor storms and normal flow-off are catered for in the normal road prism and piped system. Major storms are routed through a linked system of road prisms and public open spaces, using attenuation techniques. The emergency system recognizes failure of the minor and major systems and provides for emergency runoff by providing continuous overland flow routes to minimize flooding of residential areas.
8. The following technical standards and design criteria are specified:
- a. Minor system designed for 2-year return period and conveyed in a combination of maximum 200m aboveground in the road prism and underground piped system.
  - b. Major system designed for 50-year return period. Difference between the 50 year and 2-year flood to be conveyed in the road prism with depths not exceeding 150mm and into designated public open spaces, using attenuation techniques.
  - c. Minimum gradients for pipelines to allow minimum flow speeds of 0.7m/s at full flow.
  - d. Maximum pipeline flow velocities to be 3.5m/s.
  - e. Stormwater pipes to be 100D as required by specific loadings or installation conditions.
  - f. Bedding to be Class C.
  - g. Minimum cover on pipes to be 800mm.
  - h. Minimum pipe diameter to be 450mm.
  - i. Gravel traps to be provided in structures (where required on steeper slopes).
  - j. Gabion (reno) mattresses to be provided at all outlets for energy dissipation and erosion protection.
  - k. Litter traps to be provided at all outlets.
  - l. Outlets to be standard concrete headwalls.

- m. Mini-attenuation ponds to be provided at all outlets.
  - n. Outlets from mini attenuation ponds to be designed as swales.
  - o. All stormwater structures on the project to be non-erosive, structurally stable and shall not induce any flooding or safety hazard.
  - p. All stormwater systems and structures to be designed by a professional engineer.
  - q. All stormwater infrastructure and structures to be inspected and cleaned on a regular basis by the landscaping and maintenance teams.
  - r. All stormwater infrastructure to be designed on SuDs principles.
  - s. Soft and porous infiltration channels or -basins to be provided where possible.
  - t. Stormwater outlets to be provided as frequently as possible in order to reduce accumulation and concentration as far as possible.
9. Stormwater technical design on this development is relatively uncomplicated due to the development being situated on top of a triple watershed. Due to the aforementioned, stormwater is hence relatively unconcentrated in the relatively small accumulation areas forming the development footprint. Three drainage zones are identified for design and report purposes and are as follows:
- a. Zone A: Approximately 93% of the site drains towards a general eastern direction towards Voorbaai and is designated as Zone A.
  - b. Zone B: Approximately 3% of the site drains towards a general northern direction and is designated as Zone B.
  - c. Zone C: Approximately 4% of the site drains towards a general southern direction and is designated as Zone C.
10. The description of the drainage zones are as follows:
- a. Zone A1 has an area of approximately 0.06ha with an estimated 1:2 year peak flow of 0.003m<sup>3</sup>/s and 1:50 year peak flow of 0.009m<sup>3</sup>/s and shall be routed from the apartment roofs into the landscaping area.
  - b. Zone A2 has an area of approximately 0.17ha with an estimated 1:2 year peak flow of 0.009m<sup>3</sup>/s and 1:50 year peak flow of 0.026m<sup>3</sup>/s and shall be routed via a formal stormwater system into a proposed internal detention pond of approximately 34m<sup>3</sup> in volume. The detention pond shall be a focus point in the development with ample landscaping and beautification. The outlet from this internal detention pond shall trickle into the swale drain as indicated.
  - c. Zone A3 has an area of approximately 0.03ha with an estimated 1:2 year peak flow of 0.002m<sup>3</sup>/s and 1:50 year peak flow of 0.005m<sup>3</sup>/s and shall be routed via a formal stormwater system into a proposed internal detention pond together with Zone A2.
  - d. Zone A4 has an area of approximately 0.05ha with an estimated 1:2 year peak flow of 0.003m<sup>3</sup>/s and 1:50 year peak flow of 0.008m<sup>3</sup>/s and shall be routed from the apartment roofs into the landscaping area.

- e. Zone A5 has an area of approximately 0.1ha with an estimated 1:2 year peak flow of 0.005m<sup>3</sup>/s and 1:50 year peak flow of 0.015m<sup>3</sup>/s and shall be routed via a formal stormwater system into a proposed internal detention pond of approximately 17m<sup>3</sup> in volume. The detention pond shall be a focus point in the development with ample landscaping and beautification. The outlet from this internal detention pond shall trickle into the swale drain as indicated.
- f. Zone A6 has an area of approximately 0.09ha with an estimated 1:2 year peak flow of 0.005m<sup>3</sup>/s and 1:50 year peak flow of 0.014m<sup>3</sup>/s and shall be routed via a formal stormwater system into a proposed internal detention pond of approximately 16m<sup>3</sup> in volume. The detention pond shall be a focus point in the development with ample landscaping and beautification. The outlet from this internal detention pond shall trickle into the swale drain as indicated.
- g. Zone A7 has an area of approximately 0.06ha with an estimated 1:2 year peak flow of 0.003m<sup>3</sup>/s and 1:50 year peak flow of 0.009m<sup>3</sup>/s and shall be routed from the apartment roofs into the landscaping area.
- h. Zone A8 has an area of approximately 0.34ha with an estimated 1:2 year peak flow of 0.018m<sup>3</sup>/s and 1:50 year peak flow of 0.052m<sup>3</sup>/s. Zone A8 shall drain into the municipal culvert underneath Klipheuwel Road.
- i. Zone A9 has an area of approximately 0.17ha with an estimated 1:2 year peak flow of 0.009m<sup>3</sup>/s and 1:50 year peak flow of 0.026m<sup>3</sup>/s and shall be routed via a formal stormwater system via a proposed stormwater servitude into the swale drain as indicated.
- j. Zone A10 has an area of approximately 0.31ha with an estimated 1:2 year peak flow of 0.017m<sup>3</sup>/s and 1:50 year peak flow of 0.047m<sup>3</sup>/s and shall be routed via a formal stormwater system via a proposed stormwater servitude into the swale drain as indicated.
- k. Zone A11 has an area of approximately 0.31ha with an estimated 1:2 year peak flow of 0.017m<sup>3</sup>/s and 1:50 year peak flow of 0.047m<sup>3</sup>/s and shall be routed via a formal stormwater system via a proposed stormwater servitude into the swale drain as indicated.
- l. Zone A12 has an area of approximately 0.55ha with an estimated 1:2 year peak flow of 0.030m<sup>3</sup>/s and 1:50 year peak flow of 0.084m<sup>3</sup>/s and shall be routed via a formal stormwater system into a proposed internal detention pond of approximately 95m<sup>3</sup> in volume. The detention pond shall be a focus point in the development with ample landscaping and beautification. The outlet from this internal detention pond will drain into the municipal road reserve.
- m. Stormwater external (east) of drainage zone A currently drains into a culvert underneath Klipheuwel Road and continues east along the drainage line over Portion 206. Three options were explored for the stormwater management from this position in Klipheuwel Road. These

options are depicted on the diagram below and is discussed in the following paragraphs. A final decision shall be negotiated and included into the services agreement with the municipality.

- i. Option 1 shall take a route directly south in the road reserve of Klipheuwel Road and along the boundary of Portion 208 along the 2m building line, i.e. 1m from the erf boundary, and discard stormwater directly into the drainage line to the south. The total length of this option is 147m and shall be a 600mm concrete stormwater line. This option cuts slightly through the watershed to the south and hence will be approximately 3m deep at its deepest portion. The option is technically feasible.
  - ii. Option 2 shall take a route north in the road reserve of Klipheuwel Road, then east along the alignment of the proposed Henning Road extension, and finally south along the eastern border of Portion 206 into the drainage line. This route effectively runs around Portion 206 through which the natural drainage line runs. The total length of this option is 378m and shall be a 600mm concrete stormwater line. The vertical alignment of this route will follow a continuous downward slope. This option, although technically feasible, is the most expensive alternative.
  - iii. Option 3 shall take the direct route east along the drainage line over Portion 206. This option shall entail a municipal services (stormwater) servitude over Portion 206 to be registered. The total length of this option is 237m and shall be an open stormwater channel. This option is the most technically feasible and cost effective, but will however entail buying out a municipal stormwater servitude from the owner of Portion 206.
- n. Drainage zone B: Approximately 3% of the site drains towards a general northern direction. This area is designated as Zone B and has an area of approximately 0.14ha with an estimated 1:2 year peak flow of 0.007m<sup>3</sup>/s and 1:50 year peak flow of 0.021m<sup>3</sup>/s. Stormwater drainage at this northern corner of the development shall be discharged into Klipheuwel Road road reserve form where it shall drain naturally to the north. Energy dissipation shall be performed at this outlet with a gabion cascade and mattress design and water shall be dispersed as widely as possible.
- o. Drainage zone C: Approximately 4% of the site drains towards a general southern direction. This area is designated as Zone C and has an area of approximately 0.15ha with an estimated 1:2 year peak flow of 0.008m<sup>3</sup>/s and 1:50 year peak flow of 0.023m<sup>3</sup>/s. Stormwater drainage at this southern corner of the development shall be discharged into the adjacent property. Energy dissipation shall be performed at this outlet with a gabion cascade and mattress design and water shall be dispersed as widely as possible.

11. The swale drain running through the development from west to east shall be constructed as a porous infiltration channel with a rock or similar layer which will contribute to slowing surface flows. The swale drain shall be designed and constructed with frequent energy dissipators in the form of gabion boxes, simultaneously also vertical drops. The swale drain shall have a slope of 1% between energy dissipators in order to maximize energy dissipation and infiltration into the subsurface. This will provide filtration, removal of urban pollutants (e.g. hydrocarbons), provide attenuation, and dissipate energy of storm water flows through increased roughness (compared to pipes and concrete V-drains). The swale drain shall simultaneously be designed to be a focus point with ample landscaping and beautification.
12. Energy dissipation shall be performed at all outlets with a gabion cascade and gabion mattress design. Water shall simultaneously be dispersed to the maximum at all outlets.

With reference to all of the conclusions above, it can holistically be concluded that the proposed development can be designed and constructed to acceptable specifications and standards from a stormwater management perspective.

## **6.2 Recommendations**

With reference to the conclusions above, the following is recommended:

1. That all conceptual and preliminary design specifications and standards contained in this report be accepted and approved.
2. That all detail designs be performed by a professional engineer in line with the proposals contained in the report.
3. That all detail designs be performed to the satisfaction of the local municipality, relevant provincial and national government departments and other authorities.
4. That all stormwater management plan design aspects be included into the services agreement with the local municipality.

It is the holistic recommendation that the proposed development be approved from a stormwater management perspective subject to the implementation of the conclusions and recommendations contained in this report.

## **7 ADDENDA**

---

### **7.1 Addendum 1 – Site development plans**

### **7.2 Addendum 2 – Stormwater management plan drawings & typical details**

**ADDENDUM 1**  
**SITE DEVELOPMENT PLAN**



## **ADDENDUM 2**

### **STORMWATER MANAGEMENT PLAN DRAWINGS & TYPICAL DETAILS**

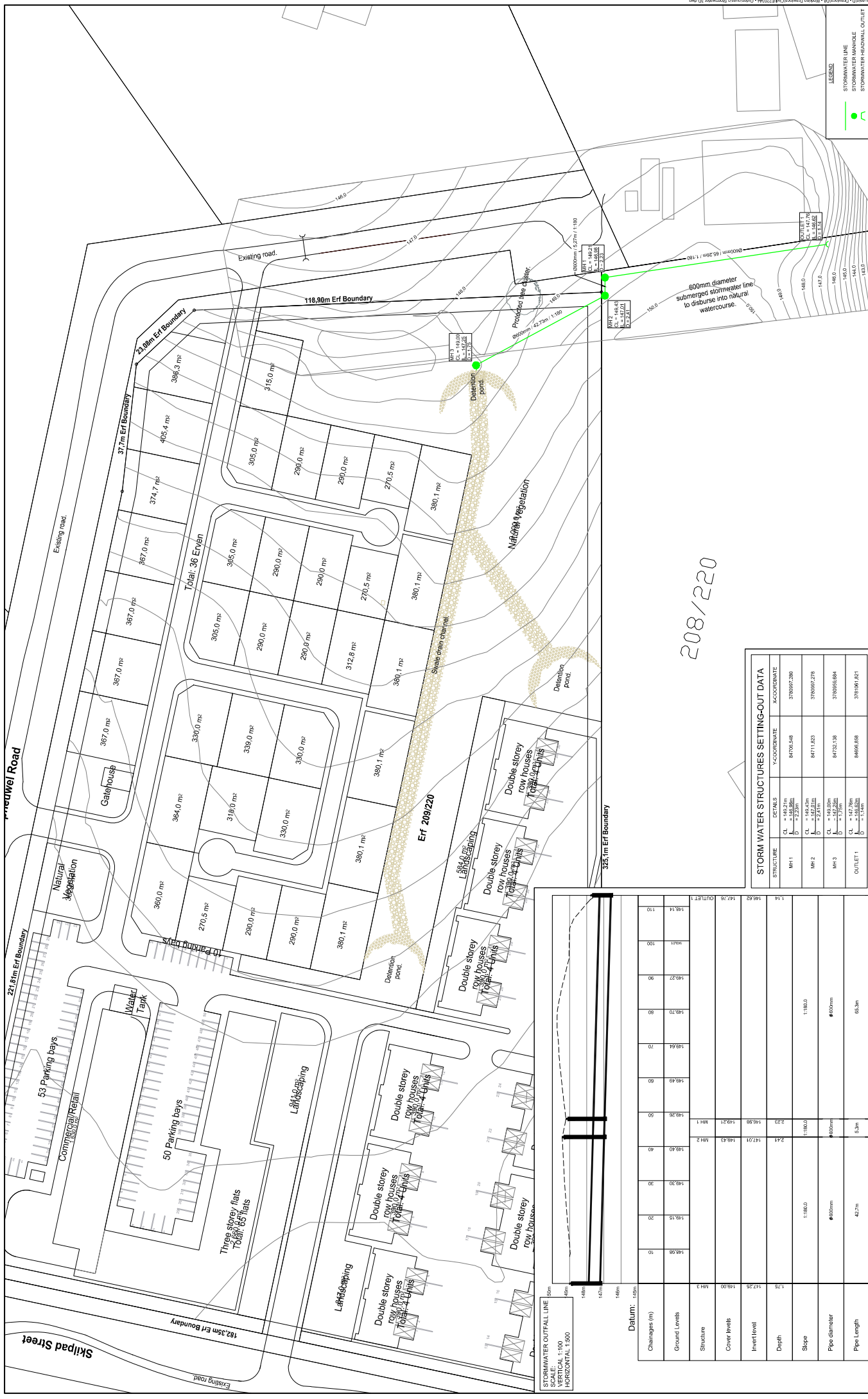

Scale: 1:500

Original Size A1

Contract No: E220344

Drawing No: E220344/C/SW01

Revision: D

COMPANY IS SET TO RELEASE CONSULTING SERVICES (PTY) LTD IN TERMS OF THE COMPACT ACT 88 OF 1995.

Name	MP	Signature
Design	MP	
Drawn	MP	
Checked	HL	
Approved	HL	
Pr. No.		

Project: OUITENIQUASIG PORTION 209 OF FARM 220 VYF BRAKKE FONTEIN, AALWYNDAL

Plan Description: STORMWATER OUTFALL LINE LAYOUT

STORM WATER STRUCTURES SETTING-OUT DATA

STRUCTURE	DETAILS	X-COORDINATE	Y-COORDINATE
MH 1	CL = 182.3m D = 2.20m	370697.230	84706.548
MH 2	CL = 184.0m D = 2.20m	370697.278	84711.625
MH 3	CL = 183.0m D = 1.20m	370695.084	84732.138
OUTLET 1	CL = 182.70m D = 1.20m	371106.182	84606.858

STORMWATER OUTFALL LINE

SCALE: VERTICAL 1:100 HORIZONTAL 1:500

Changes (m)	Ground Levels	Structure	Cover Levels	Invert Level	Depth	Slope	Pipe diameter	Pipe Length
148.14	148.14	MH 1	148.14	148.14	1.100	1:100	600mm	42.7m
148.16	148.16	MH 2	148.16	148.16	1.100	1:100	600mm	5.3m
148.18	148.18	MH 3	148.18	148.18	1.100	1:100	600mm	5.3m
148.20	148.20	OUTLET 1	148.20	148.20	1.100	1:100	600mm	5.3m

Client/Employee

STRUCTURE	DETAILS	X-COORDINATE	Y-COORDINATE
MH 1	CL = 182.3m D = 2.20m	370697.230	84706.548
MH 2	CL = 184.0m D = 2.20m	370697.278	84711.625
MH 3	CL = 183.0m D = 1.20m	370695.084	84732.138
OUTLET 1	CL = 182.70m D = 1.20m	371106.182	84606.858

62 Volsburg Street  
George 6520  
P O Box 8962  
George 6529  
Tel: +27 44 884 1138  
Email: info@element.co.za

**ELEMENT**  
Consulting Engineers  
A FIFTH DIMENSION TO ENGINEERING

No.	Date	Description	Rev.	By

- NOTES:**
- ALL DIMENSIONS AND LEVELS TO BE CHECKED AGAINST THE DRAWING AND ANY DISCREPANCIES TO BE REFERRED TO ENGINEER.
  - GENERAL CONCRETE TO BE CLASS 20/19.
  - STRUCTURAL CONCRETE TO BE CLASS 30/19.
  - ALL WORK TO BE DONE IN ACCORDANCE WITH THE SANS 10400 SERIES AND A WORKSHOP DRAWING SHALL BE SUBMITTED TO THE ENGINEER FOR APPROVAL.
  - 125 MPa OF REINFORCEMENT TO BE ALLOWED PER M<sup>2</sup> OF CONCRETE.

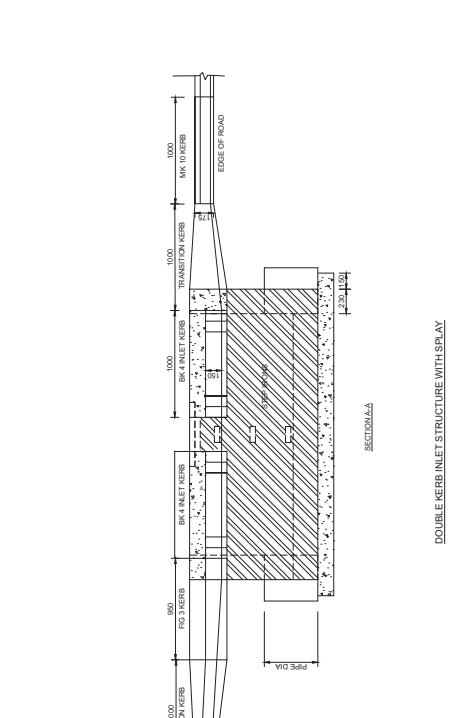
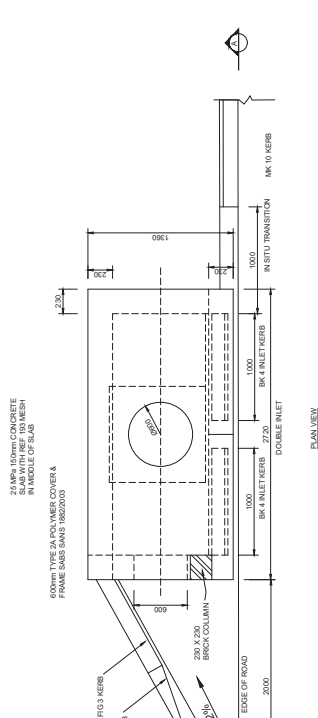
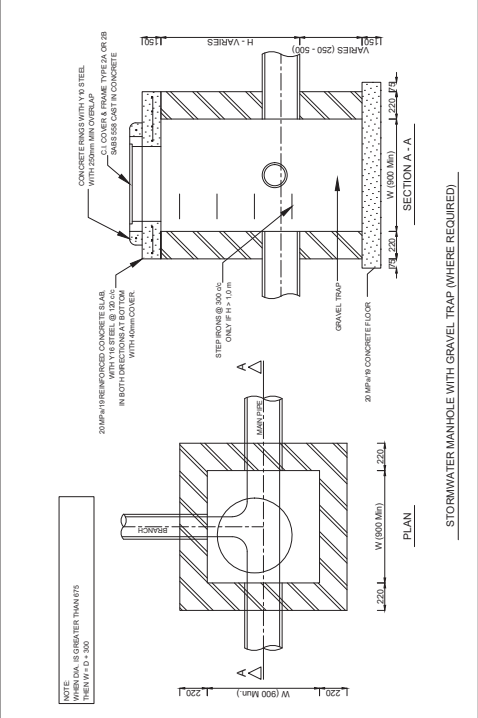

Scale	NTS	Name	MP
Original Size	A1	Designed	MP
Contract No.	1701561	Drawn	MP
Drawing No.	1701561/C/SW20	Checked	HL
Revision	A	Approved	HL
		Pi. No.	

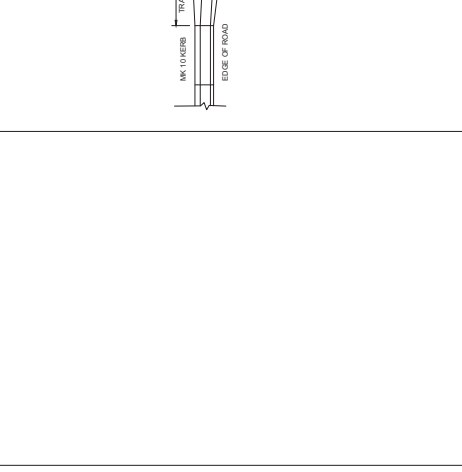
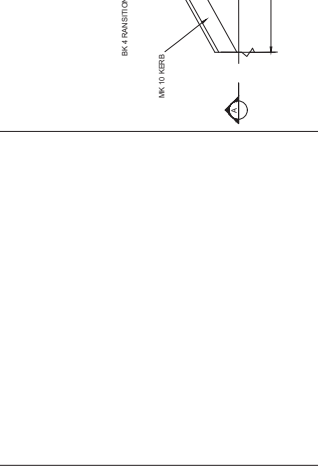
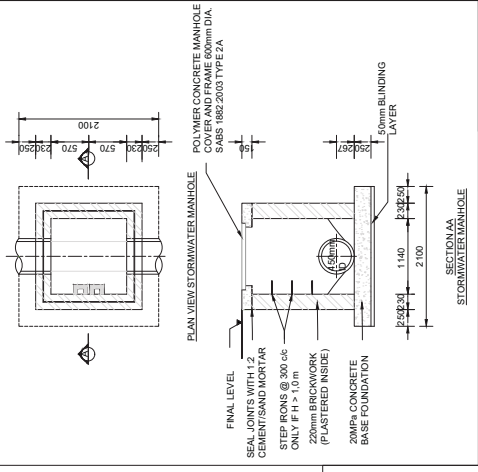

Client/Engineer	AALWYNDAL 220-209 OUTENIQUASIG		
Project	STORMWATER TYPICAL DETAILS		
Plan Description	STORMWATER TYPICAL DETAILS		

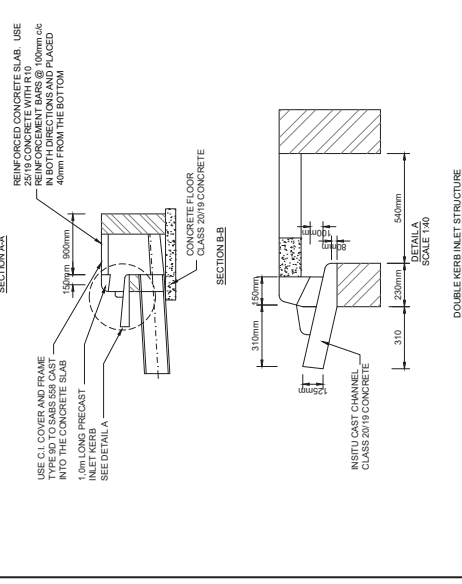
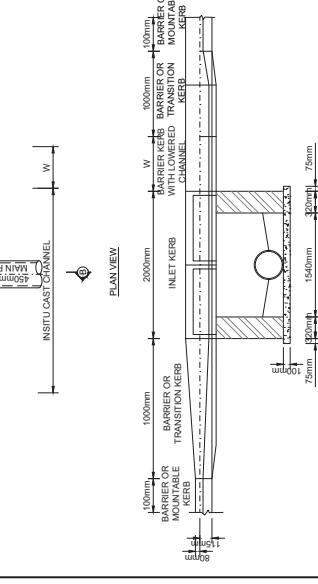
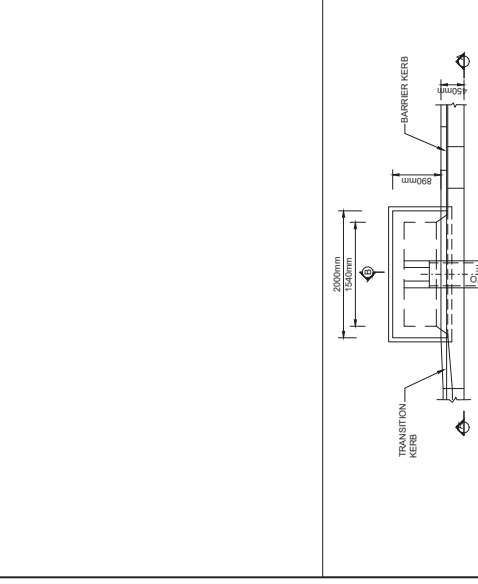

82 Nelspruit Street, George 6520 P O Box 6902 George 6520 Tel +27 44 884 1188 E-Mail: info@element.co.za	<b>ELEMENT</b> Consulting Engineers A FIFTH DIMENSION TO ENGINEERING		
Rev	Date	Description	by
A	14/07/2024	PRELIMINARY DESIGN	MP

